

A. Introduction

1. **Title: Undervoltage Load Shedding**
2. **Number: PRC-010-1**
3. **Purpose:** To establish an integrated and coordinated approach to the design, evaluation, and reliable operation of Undervoltage Load Shedding Programs (UVLS Programs).
4. **Applicability:**
 - 4.1. **Functional Entities:**
 - 4.1.1 Planning Coordinator
 - 4.1.2 Transmission Planner
 - 4.1.3 Undervoltage load shedding (UVLS) entities – Distribution Providers and Transmission Owners responsible for the ownership, operation, or control of UVLS equipment as required by the UVLS Program established by the Transmission Planner or Planning Coordinator.
5. **Background:**

PRC-010-1 – Undervoltage Load Shedding is a consolidation and revision of the following Reliability Standards:

- PRC-010-0 – Assessment of the Design and Effectiveness of UVLS Program
- PRC-020-1 – Under-Voltage Load Shedding Program Database
- PRC-021-1 – Under-Voltage Load Shedding Program Data
- PRC-022-1 – Under-Voltage Load Shedding Program Performance

The UVLS Standard Drafting Team (or drafting team) developed the revised PRC-010-1 to meet the following objectives:

- Address the FERC directive in Order No. 693, Paragraph 1509 to modify PRC-010-0 to require an integrated and coordinated approach to all protection systems.
- Replace the applicability to and involvement of the Regional Reliability Organization (RRO) in PRC-020-1 and PRC-021-1.
- Consolidate the UVLS-related standards into one comprehensive standard (similar to the construct of FERC-approved PRC-006-1– Automatic Underfrequency Load Shedding).
- Clearly identify and separate centrally controlled undervoltage-based load shedding due to the reliability requirements needed for this type of load shedding as compared to other UVLS systems.
- Create a single results-based standard that addresses current reliability issues associated with UVLS.

B. Requirements and Measures

- R1.** Each Planning Coordinator or Transmission Planner that is developing a UVLS Program shall evaluate its effectiveness and subsequently provide the UVLS Program’s specifications and implementation schedule to the UVLS entities responsible for implementing the UVLS Program. The evaluation shall include, but is not limited to, studies and analyses that show: *[Violation Risk Factor: High] [Time Horizon: Long-term Planning]*
- 1.1.** The implementation of the UVLS Program resolves the identified undervoltage issues that led to its development and design.
 - 1.2.** The UVLS Program is integrated through coordination with generator voltage ride-through capabilities and other protection and control systems, including, but not limited to, transmission line protection, autoreclosing, Remedial Action Schemes, and other undervoltage-based load shedding programs.
- M1.** Acceptable evidence may include, but is not limited to, date-stamped studies and analyses, reports, or other documentation detailing the effectiveness of the UVLS Program, and date-stamped communications showing that the UVLS Program specifications and implementation schedule were provided to UVLS entities.
- R2.** Each UVLS entity shall adhere to the UVLS Program specifications and implementation schedule determined by its Planning Coordinator or Transmission Planner associated with UVLS Program development per Requirement R1 or with any Corrective Action Plans per Requirement R5. *[Violation Risk Factor: High] [Time Horizon: Long-term Planning]*
- M2.** Acceptable evidence must include date-stamped documentation on the completion of actions and may include, but is not limited to, identifying the equipment armed with UVLS relays, the UVLS relay settings, associated Load summaries, work management program records, work orders, and maintenance records.
- R3.** Each Planning Coordinator or Transmission Planner shall perform a comprehensive assessment to evaluate the effectiveness of each of its UVLS Programs at least once every 60 calendar months. Each assessment shall include, but is not limited to, studies and analyses that evaluate whether: *[Violation Risk Factor: Medium] [Time Horizon: Long-term Planning]*
- 3.1.** The UVLS Program resolves the identified undervoltage issues for which the UVLS Program is designed.
 - 3.2.** The UVLS Program is integrated through coordination with generator voltage ride-through capabilities and other protection and control systems, including, but not limited to, transmission line protection, autoreclosing, Remedial Action Schemes, and other undervoltage-based load shedding programs.
- M3.** Acceptable evidence may include, but is not limited to, date-stamped reports or other documentation detailing the assessment of the UVLS Program.
- R4.** Each Planning Coordinator or Transmission Planner shall, within 12 calendar

PRC-010-1 – Undervoltage Load Shedding

months of an event that resulted in a voltage excursion for which its UVLS Program was designed to operate, perform an assessment to evaluate whether its UVLS Program resolved the undervoltage issues associated with the event. *[Violation Risk Factor: Medium] [Time Horizon: Operations Planning]*

- M4.** Acceptable evidence may include, but is not limited to, date-stamped event data, event analysis reports, or other documentation detailing the assessment of the UVLS Program.
- R5.** Each Planning Coordinator or Transmission Planner that identifies deficiencies in its UVLS Program during an assessment performed in either Requirement R3 or R4 shall develop a Corrective Action Plan to address the deficiencies and subsequently provide the Corrective Action Plan, including an implementation schedule, to UVLS entities within three calendar months of completing the assessment. *[Violation Risk Factor: Medium] [Time Horizon: Operations Planning]*
- M5.** Acceptable evidence must include a date-stamped Corrective Action Plan that addresses identified deficiencies and may also include date-stamped reports or other documentation supporting the Corrective Action Plan. Evidence should also include date-stamped communications showing that the Corrective Action Plan and an associated implementation schedule were provided to UVLS entities.
- R6.** Each Planning Coordinator that has a UVLS Program in its area shall update a database containing data necessary to model the UVLS Program(s) in its area for use in event analyses and assessments of the UVLS Program at least once each calendar year. *[Violation Risk Factor: Lower] [Time Horizon: Operations Planning]*
- M6.** Acceptable evidence may include, but is not limited to, date-stamped spreadsheets, database reports, or other documentation demonstrating a UVLS Program database was updated.
- R7.** Each UVLS entity shall provide data to its Planning Coordinator according to the format and schedule specified by the Planning Coordinator to support maintenance of a UVLS Program database. *[Violation Risk Factor: Lower] [Time Horizon: Operations Planning]*
- M7.** Acceptable evidence may include, but is not limited to, date-stamped emails, letters, or other documentation demonstrating data was provided to the Planning Coordinator as specified.
- R8.** Each Planning Coordinator that has a UVLS Program in its area shall provide its UVLS Program database to other Planning Coordinators and Transmission Planners within its Interconnection, and other functional entities with a reliability need, within 30 calendar days of a written request. *[Violation Risk Factor: Lower] [Time Horizon: Operations Planning]*
- M8.** Acceptable evidence may include, but is not limited to, date-stamped emails, letters, or other documentation demonstrating that the UVLS Program database was provided within 30 calendar days of receipt of a written request.

C. Compliance

1. Compliance Monitoring Process

1.1. Compliance Enforcement Authority

As defined in the NERC Rules of Procedure, “Compliance Enforcement Authority” means NERC or the Regional Entity in their respective roles of monitoring and enforcing compliance with the NERC Reliability Standards.

1.2. Evidence Retention

The following evidence retention periods identify the period of time an entity is required to retain specific evidence to demonstrate compliance. For instances where the evidence retention period specified below is shorter than the time since the last audit, the Compliance Enforcement Authority may ask an entity to provide other evidence to show that it was compliant for the full-time period since the last audit.

The Planning Coordinator, Transmission Planner, Distribution Provider, and Transmission Owner shall keep data or evidence to show compliance as identified below unless directed by its Compliance Enforcement Authority to retain specific evidence for a longer period of time as part of an investigation.

The applicable entity shall retain documentation as evidence for six calendar years.

If an applicable entity is found non-compliant, it shall keep information related to the non-compliance until mitigation is complete and approved, or for the time specified above, whichever is longer.

The Compliance Enforcement Authority shall keep the last audit records and all requested and submitted subsequent audit records.

1.3. Compliance Monitoring and Assessment Processes:

“Compliance Monitoring and Assessment Processes” refers to the identification of the processes that will be used to evaluate data or information for the purpose of assessing performance or outcomes with the associated reliability standard.

1.4. Additional Compliance Information

None

Table of Compliance Elements

R #	Time Horizon	VRF	Violation Severity Levels			
			Lower VSL	Moderate VSL	High VSL	Severe VSL
R1	Long-term Planning	High	N/A	N/A	N/A	The applicable entity that developed the UVLS Program failed to evaluate the program’s effectiveness and subsequently provide the UVLS Program’s specifications and implementation schedule to UVLS entities in accordance with Requirement R1, including the items specified in Parts 1.1 and 1.2.
R2	Long-term Planning	High	N/A	N/A	The applicable entity failed to adhere to the UVLS Program specifications in accordance with Requirement R2. OR The applicable entity failed to adhere to the implementation schedule in accordance with Requirement R2.	The applicable entity failed to adhere to the UVLS Program specifications and implementation schedule in accordance with Requirement R2.

PRC-010-1 – Undervoltage Load Shedding

R #	Time Horizon	VRF	Violation Severity Levels			
			Lower VSL	Moderate VSL	High VSL	Severe VSL
R3	Long-term Planning	Medium	N/A	N/A	N/A	The applicable entity failed to perform an assessment at least once during the 60 calendar months in accordance with Requirement R3, including the items specified in Parts 3.1 and 3.2.
R4	Operations Planning	Medium	The applicable entity performed an assessment in accordance with Requirement R4 within a time period greater than 12 calendar months but less than or equal to 13 calendar months after an applicable event.	The applicable entity performed an assessment in accordance with Requirement R4 within a time period greater than 13 calendar months but less than or equal to 14 calendar months after an applicable event.	The applicable entity performed an assessment in accordance with Requirement R4 within a time period greater than 14 calendar months but less than or equal to 15 calendar months after an applicable event.	The applicable entity performed an assessment in accordance with Requirement R4 within a time period greater than 15 calendar months after an applicable event. OR The applicable entity failed to perform an assessment in accordance with Requirement R4.

PRC-010-1 – Undervoltage Load Shedding

R #	Time Horizon	VRF	Violation Severity Levels			
			Lower VSL	Moderate VSL	High VSL	Severe VSL
R5	Operations Planning	Medium	The applicable entity developed a Corrective Action Plan and provided it to UVLS entities in accordance with Requirement R5 but was late by less than or equal to 15 calendar days.	The applicable entity developed a Corrective Action Plan and provided it to UVLS entities in accordance with Requirement R5 but was late by more than 15 calendar days but less than or equal to 30 calendar days.	The applicable entity developed a Corrective Action Plan and provided it to UVLS entities in accordance with Requirement R5 but was late by more than 30 calendar days but less than or equal to 45 calendar days.	The applicable entity developed a Corrective Action Plan and provided it to UVLS entities in accordance with Requirement R5 but was late by more than 45 calendar days. OR The responsible entity failed to develop a Corrective Action Plan or provide it to UVLS entities in accordance with Requirement R5.
R6	Operations Planning	Lower	The applicable entity updated the database in accordance with Requirement R6 but was late by less than or equal to 30 calendar days.	The applicable entity updated the database in accordance with Requirement R6 but was late by more than 30 calendar days but less than or equal to 60 calendar days.	The applicable entity updated the database in accordance with Requirement R6 but was late by more than 60 calendar days but less than or equal to 90 calendar days.	The applicable entity updated the database in accordance with Requirement R6 but was late by more than 90 calendar days. OR The applicable entity failed to update the database in accordance with Requirement R6.

PRC-010-1 – Undervoltage Load Shedding

R #	Time Horizon	VRF	Violation Severity Levels			
			Lower VSL	Moderate VSL	High VSL	Severe VSL
R7	Operations Planning	Lower	<p>The applicable entity provided data in accordance with Requirement R7 but was late by less than or equal to 30 calendar days per the specified schedule.</p> <p>OR</p> <p>The applicable entity provided data in accordance with Requirement R7 but the data was not provided according to the specified format.</p>	<p>The applicable entity provided data in accordance with Requirement R7 but was late by more than 30 calendar days but less than or equal to 60 calendar days per the specified schedule.</p>	<p>The applicable entity provided data in accordance with Requirement R7 but was late by more than 60 calendar days but less than or equal to 90 calendar days per the specified schedule.</p>	<p>The applicable entity provided data in accordance with Requirement R7 but was late by more than 90 calendar days per the specified schedule.</p> <p>OR</p> <p>The applicable entity failed to provide data in accordance with Requirement R7.</p>
R8	Operations Planning	Lower	<p>The applicable entity provided its UVLS Program database in accordance with Requirement R8 but was late by less than or equal to 15 calendar days.</p>	<p>The applicable entity provided its UVLS Program database in accordance with Requirement R8 but was late by more than 15 calendar days but less than or equal to 30 calendar days.</p>	<p>The applicable entity provided its UVLS Program database in accordance with Requirement R8 but was late by more than 30 calendar days but less than or equal to 45 calendar days.</p>	<p>The applicable entity provided its UVLS Program database in accordance with Requirement R8 but was late by more than 45 calendar days.</p> <p>OR</p> <p>The applicable entity failed to provide its UVLS Program database in accordance with Requirement R8.</p>

D. Regional Variances

None.

E. Interpretations

None.

F. Associated Documents

None.

Guidelines and Technical Basis

Introduction

PRC-010-1 is a single, comprehensive standard that addresses the same reliability principles outlined in its legacy standards, PRC-010-0, PRC-020-1, PRC-021-1, and PRC-022-1. The standard also addresses a FERC directive from Order No. 693, Paragraph 1509. This paragraph directs NERC to develop a modification to PRC-010-0 that requires an integrated and coordinated approach to all protection systems, including generators and transmission lines, generators' low voltage ride-through capabilities, and underfrequency load shedding (UFLS) and UVLS programs.

Since FERC-approved PRC-006-1 – Automatic Underfrequency Load Shedding was developed under a similar construct of combining existing standards and addressing a FERC Order No. 693 directive, the drafting team looked to this standard as a guide. With the understanding that UVLS and UFLS systems have fundamental differences, the drafting team adopted PRC-006-1's industry-vetted reliability principles and language as applicable to UVLS Programs.

The drafting team's established purpose for PRC-010-1 is to clearly define the responsibilities of applicable entities to pursue an integrated and coordinated approach to the design, evaluation, and reliable operation of UVLS Programs. Since the need for and design of UVLS Programs is unique to each system preservation footprint, the intent of the standard is to provide a framework of reliability requirements for such programs to which each individual entity can apply its program's specific considerations and characteristics. The drafting team emphasizes that PRC-010-1 does not require a mandatory UVLS Program, nor does this standard address the need to have a UVLS Program. PRC-010-1 applies only after an entity has determined the need for a UVLS Program as a result of its own planning studies.

The drafting team provides the following discussion to support the approach to the standard. The information is meant to enhance the understanding of the reliability needs and deliverable expectations of each requirement, supported as necessary by technical principles and industry experience.

The design and characteristics of a centrally controlled undervoltage-based load shedding system are commensurate with a Special Protection System (SPS) or Remedial Action Scheme (RAS), therefore, the drafting team maintains that this type of load shedding should be covered by SPS-or-RAS-related Reliability Standards. Therefore, PRC-010-1 introduces a new Glossary of Terms Used in NERC Reliability Standards term, UVLS Program, to establish the applicability of PRC-010-1 to automatic load shedding programs consisting of distributed relays and controls used to mitigate undervoltage conditions impacting the Bulk Electric System (BES), leading to voltage instability, voltage collapse, or Cascading. Undervoltage-based load shedding that does not have such an impact as determined by the Planning Coordinator or Transmission Planner is not included. It is further noted that this term excludes centrally controlled undervoltage-based load shedding.

Subsequently, since the current Glossary of Terms Used in NERC Reliability Standards definition of Special Protection System excludes UVLS, concurrent Project 2010-05.2 – Special Protection Systems (Phase 2 of Protection Systems) will adjust the definition to exclude only UVLS Programs as defined above and therefore include centrally controlled undervoltage-

Guidelines and Technical Basis

based load shedding. Of note, the drafting team for Project 2010-05.2 is proposing to change the term from Special Protection System to Remedial Action Scheme. Accordingly, PRC-010-1 uses the term Remedial Action Scheme instead of Special Protection System. In the current inventory of NERC Reliability Standards, there is one instance of the term undervoltage load shedding program, which is in NUC-001-2.1. Project 2012-13–Nuclear Plant Interface Coordination has adjusted the language of this reference in proposed NUC-001-3 to eliminate any potential confusion of a lowercase usage of a defined term. Likewise, future projects containing standards that feature variations of the term (e.g., undervoltage load shedding system) will also be advised to consider the newly defined term.

Requirements of the revised Reliability Standard PRC-010-1 meet the following objectives:

- Evaluate a UVLS Program’s effectiveness prior to implementation, including the program’s coordination with other protection systems and generator voltage ride-through capabilities.
- Adhere to UVLS Program specifications and implementation schedule.
- Perform periodic assessment and performance analysis of UVLS Programs and resolve identified deficiencies.
- Maintain and share UVLS Program data.

Also of note, Project 2009-03 – Emergency Operations is proposing EOP-011-1, which, as part of the overall revisions, retires specific requirements from EOP-003-2 – Load Shedding Plans to eliminate identified redundancy between PRC-010-1 and EOP-003-2. In addition, the UVLS drafting team’s intention is for PRC-004 to address Misoperations of UVLS Programs that are intended to trip one or more BES Elements. A change to make these types of UVLS Programs explicitly applicable to PRC-004 will be addressed once PRC-004-3 – Protection System Misoperation Identification and Correction is completed under Project 2010-05.1 – Misoperations (Phase 1 of Protection Systems).

Guidelines and Technical Basis

Guidelines for UVLS Program Definition

The definition for the term UVLS Program includes automatic load shedding programs that utilize only voltage inputs at locations where action is taken to shed load. As such, the failure of a single component is unlikely to affect the reliable operation of the program.

The definition for the term UVLS Program excludes centrally controlled undervoltage-based load shedding, which utilizes inputs from multiple locations and may also utilize inputs other than voltages (such as generator reactive reserves, facility loadings, equipment statuses, etc.). The design and characteristics of a centrally controlled undervoltage-based load shedding system are the same as that of a RAS, wherein load shedding is the remedial action. Therefore, just like for a RAS, the failure of a single component can compromise the reliable operation of centrally controlled undervoltage-based load shedding.

To ensure that the applicability of the standard is to only those undervoltage-based load shedding systems whose performance has an impact on system reliability, a UVLS Program must mitigate risk of one or more of the following: voltage instability, voltage collapse, or Cascading impacting the BES. An example of a program that would not fall under this category is undervoltage-based load shedding installed to mitigate damage to equipment or local loads that are directly affected by the low voltage event.

Below is an example of a BES subsystem for which UVLS system could be used as a solution to mitigate various issues following the loss of the 345 kV double circuit line between bus A and bus B. If the consequence of this Contingency does not impact the BES by leading to voltage instability, voltage collapse, or Cascading involving the BES, UVLS system (installed at either, or both, bus B and D) used to mitigate this case would not fall under the definition of a UVLS Program. However, if this same UVLS system would be used to mitigate Adverse Reliability Impact outside this contained area, it would be classified as a wide-area undervoltage problem and would fall under the definition of UVLS Program.

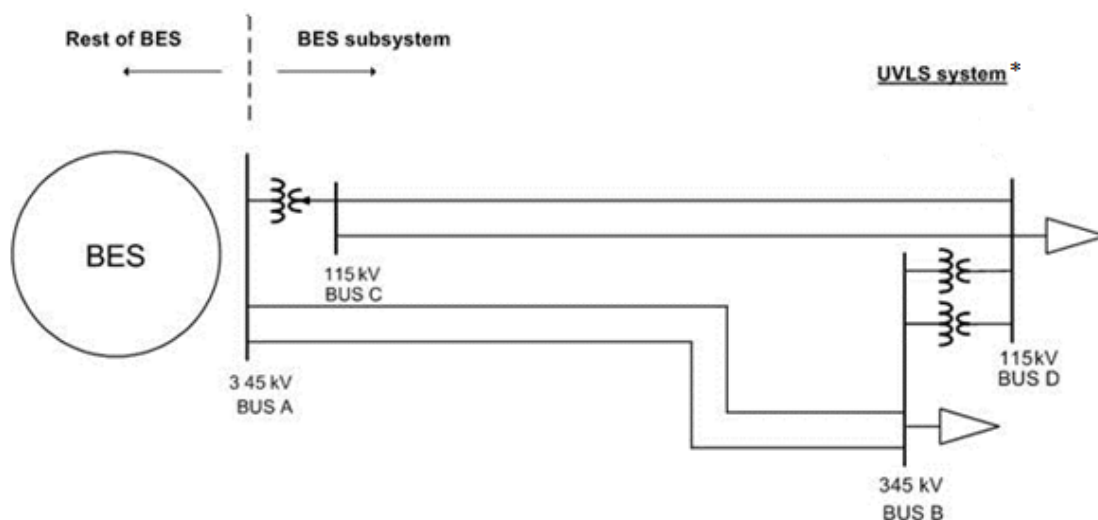

*UVLS systems may be installed at either, or both, bus B and D

High Level Requirement Overview

Requirement	Entity	Evaluate Program Effectiveness	Adhere to Program Specifications and Schedule	Perform Program Assessment (Periodic or Performance)	Develop a CAP to Address Program Deficiencies	Update and/or Share Program Data
R1	PC or TP	X				
R2	UVLS entity		X			
R3	PC or TP	X		X		
R4	PC or TP	X		X		
R5	PC or TP				X	
R6	PC					X
R7	UVLS entity					X
R8	PC					X

Guidelines for Requirement R1:

A UVLS Program may be developed and implemented to either serve as a safety net system protection measure against unforeseen extreme Contingencies or to achieve specific system performance for known transmission Contingencies for which dropping of load is allowed under Transmission Planning (TPL) Reliability Standards. Regardless of the purpose, it is important that the UVLS Program being implemented is effective in terms that it mitigates undervoltage conditions impacting the Bulk Electric System (BES), leading to voltage instability, voltage collapse, or Cascading. Consideration should be given to voltage set points and time delays, rate of voltage decay or recovery, power flow levels, etc. when designing a UVLS Program.

For the UVLS Program to be effective in achieving its goal, it is also necessary that the UVLS Program is coordinated with generator voltage ride-through capabilities and other protection and control systems that may have an impact on the performance of the UVLS Program. Some of these protection and control systems may include, but are not limited to, transmission line protection, RAS, other undervoltage-based load shedding programs, autoreclosing, and controls of shunt capacitors, reactors, and static var systems (SVSs).

For example, if the purpose of a UVLS Program is to mitigate fault-induced delayed voltage recovery (FIDVR) events in a large load center that also includes local generation, it is important that such a UVLS Program is coordinated with local generators’ voltage ride-through capabilities. Generators in the vicinity of a load center are critical to providing dynamic voltage support to the system during FIDVR events. To maximize the benefit of on-line generation, the best practice may be to shed load prior to generation trip. However, occasionally, it may be best to let generation trip prior to load shed. Therefore, the impact of generation tripping should be considered while designing a UVLS Program.

Guidelines and Technical Basis

Another example that can be highlighted is the coordination of a UVLS Program with automatic shunt reactor tripping devices if there are any on the system. Most likely, any shunt reactors on the system will trip off automatically after some time delay during low voltage conditions. In such cases, shunt reactors should be tripped before the load is shed to preserve the system. This may require coordination of time delays associated with the UVLS Program with shunt reactor tripping devices.

Examples given above demonstrate that, for a UVLS Program to be effective, proper consideration should be given to coordination of a UVLS Program with generator ride-through capabilities and other protection and control systems.

Guidelines for Requirement R2:

Once a Planning Coordinator or Transmission Planner has identified a need for a UVLS Program, the Planning Coordinator or Transmission Planner will develop a program that includes specifications and an implementation schedule, which are then provided to UVLS entities per Requirement R1. Specifications may include voltage set points, time delays, amount of load to be shed, the location at which load needs to be shed, etc. If UVLS entities do not implement the UVLS Program according to the specifications and schedule provided, the UVLS Program may not be effective and may not achieve its intended goal. The UVLS entity must document that all necessary actions were completed to implement the UVLS Program.

Similarly, when a Corrective Action Plan (CAP) to address UVLS Program deficiencies is developed by the Planning Coordinator or Transmission Planner and provided to UVLS entities per Requirement R5, UVLS entities must comply with the CAP and its associated implementation schedule to ensure that the UVLS Program is effective. The UVLS entity is required to complete the actions specified in the CAP, document the plan implementation, and retain the appropriate evidence to demonstrate implementation and completion.

Deferrals or other relevant changes to the UVLS Program specifications or CAP need to be documented so that the record includes not only what was planned, but what was implemented. Depending on the planning and documentation format used by the responsible entity, evidence of a successful execution could consist of signed-off work orders, printouts from work management systems, spreadsheets of planned versus completed work, timesheets, work inspection reports, paid invoices, photographs, walk-through reports, or other evidence.

For example, documentation of a CAP provides an auditable progress and completion confirmation for the identified UVLS Program deficiency:

CAP Example 1 - Corrective actions for a quick triggering problem; preemptive actions for similar installations:

PC or TP obtains fault records from a UVLS entity that participates in its UVLS Program that indicate a group of UVLS relays triggered at the appropriate undervoltage level but with shorter delays than expected. The PC or TP directed the UVLS entity to schedule on-site inspections within three weeks.

Guidelines and Technical Basis

The results of the inspection confirmed that the delay-time programmed on the relays was 60 cycles instead of 90 cycles. The PC or TP then directed the UVLS entity to correct to a 90-cycle time delay setting of the UVLS relays identified to have shorter time delay settings within eight weeks.

Applicability to other UVLS relays: The PC or TP then developed a schedule with the UVLS entity to verify and adjust all remaining UVLS relays time delay settings within a one-year period.

The PC or TP verified completion of verification and adjustment of the time delay settings for all of the UVLS entity's equipment that participates in the PC or TP UVLS Program

CAP Example 2 - Corrective actions for a firmware problem; preemptive actions for similar installations:

PC or TP obtains fault records on 6/4/2014 from a UVLS entity that participates in its UVLS Program. The UVLS entity also provided the fault records to the manufacturer, who responded on 6/11/2014 that the misoperation of the UVLS relay was caused by a bug in version 2 firmware, and recommended installing version 3 firmware. The PC or TP approved the UVLS entity's plan to schedule Version 3 firmware installation on 6/12/2014.

Applicability to other UVLS relays: The PC or TP then developed a schedule with the UVLS entity to install firmware version 3 at all of the UVLS entity's UVLS relays that are determined to be programmed with version 2 firmware. The completion date was scheduled no-later-than 12/31/2014.

The firmware replacements were completed on 12/4/2014.

Guidelines for Requirement R3:

In addition to the initial studies required to develop a UVLS Program, periodic comprehensive assessments (detailed analyses) are required to ensure its continued effectiveness. This assessment should be completed at least once every 60 calendar months to capture the accumulated effects of minor changes to the system that have occurred since the last assessment was completed. However, at any point in time, a Planning Coordinator or Transmission Planner may also determine that a material change to system topology or operating conditions affects the performance of the UVLS Program and therefore necessitates the same comprehensive assessment. Regardless of the trigger, each assessment should include an evaluation of each UVLS Program to ensure the continued integration through coordination.

This comprehensive assessment supplements the TPL-001-4 annual assessment requirement to evaluate the impact of protection systems. The 60-month period is the same time frame used in TPL-001-4 and in PRC-006-1.

Guidelines and Technical Basis

With respect to situations in which a material change to system and topology or operating conditions would necessitate a comprehensive assessment of the UVLS Program, it is understood that the term material change is not transportable on a continent-wide basis. This determination must be made by the Planning Coordinator or Transmission Planner and should be accompanied by documentation to support the technical rationale for determining material changes.

As specified in Requirement R3, a comprehensive assessment must be performed at least once every 60 calendar months. If a Planning Coordinator or Transmission Planner conducts a comprehensive assessment sooner for the reasons discussed above, the 60-month time period would restart upon completion of this assessment.

Guidelines for Requirement R4:

The goal of the assessment required in Requirement R4 is to evaluate whether the UVLS Program resolved the undervoltage issues for an event that occurred on the system. It is expected that the assessment should include event data analysis, such as the relevant sequence of events leading to the undervoltage conditions (e.g., Contingencies, operation of protection systems, and RAS) and field measurements useful to analyzing the behavior of the system. A comprehensive description of the UVLS Program operation should be presented, including conditions of the trigger (e.g., voltage levels, time delays) and amount of load shed for each affected substation. Assessment of the event shall be performed to evaluate the level of performance of the program for the event of interest and to identify deficiencies to be included in a CAP per Requirement R5.

The studies and analyses showing the effectiveness of the UVLS Program can be similar to what is required in Requirements R1 and R3, but should include a clear link between the evaluation of effectiveness (in studies using simulations) and the analysis of the event (with measurements and event data) that actually occurred. For example, differences between the expected and actual system behavior for the event of interest should be discussed and modeling assumptions should be evaluated. Important discrepancies between the simulations and the actual event should be investigated.

Considering the importance of an event that involves the operation of a UVLS Program, the 12-calendar-month period provides adequate time to analyze the event and perform an assessment while identifying deficiencies within a reasonable time. This time period is also required in PRC-006-1.

Guidelines for Requirement R5:

Requirement R5 promotes the prudent correction of an identified problem during assessment evaluations of each UVLS Program. Per Requirements R3 and R4, an assessment of an active UVLS Program is triggered:

- Within 12 calendar months of an event that resulted in a voltage excursion for which the program was designed to operate.
- At least once every 60 months. The default time frame of 60 months or less between assessments has the intention to assure that the cumulative changes to the network and operating condition affecting the UVLS Program are evaluated.

Guidelines and Technical Basis

Since every UVLS is unique, if material changes are made to system topology or operating conditions, the Planning Coordinator or Transmission Planner will decide the degree to which the change in topology or operating condition becomes a material change sufficient to trigger an assessment of the existing UVLS Program.

A CAP is a list of actions and an associated timetable for implementation to remedy a specific problem. It is a proven tool for resolving operational problems. Per Requirement R5, the Planning Coordinator or Transmission Planner is required to develop a CAP and provide it to UVLS entities to accomplish the purpose of this requirement, which is to prevent future deficiencies in the UVLS Program, thereby minimizing risk to the system. Determining the cause of the deficiency is essential in developing an effective CAP to avoid future re-occurrence of the same problem. A CAP can be revised if additional causes are found.

Based on industry experience and operational coordination timeframes, the drafting team believes that within three calendar months from the date an assessment is completed is a reasonable time frame for development of a CAP, including time to consider alternative solutions and coordination of resources. The “within three calendar months” time frame is solely to develop a CAP, including its implementation schedule, and provide it to UVLS entities. It does not include the time needed for its implementation by UVLS entities. This implementation time frame is dictated within the CAP’s associated timetable for implementation, and the execution of the CAP according to its schedule is required in Requirement R2.

Guidelines for Requirements R6–R8

An accurate UVLS Program database is necessary for the Planning Coordinator or Transmission Planner to perform system reliability assessment studies and event analysis studies. Without accurate data, there is a possibility that annual reliability assessment studies that are performed by the Planning Coordinator or Transmission Planner can lead to erroneous results and therefore impact reliability. Also, without the accurate data, it is very difficult for the Planning Coordinator or Transmission Planner to duplicate a UVLS event and determine the root cause of the problem.

To support a UVLS Program database, it is necessary for each UVLS entity to provide accurate data to its Planning Coordinator. Each UVLS entity will provide the data according to the specified format and schedule provided by the Planning Coordinator. This is required in order for the Planning Coordinator to maintain and support a comprehensive UVLS Program database. By having a comprehensive database, the Planning Coordinator can embark on a reliability assessment or event analysis/benchmarking studies, identify the issues with the UVLS Program, and develop remedial action plans.

The UVLS Program database may include, but is not limited to the following:

- Owner and operator of the UVLS Program
- Size and location of customer load, or percent of connected load, to be interrupted

Guidelines and Technical Basis

- Corresponding voltage set points and clearing times
- Time delay from initiation to trip signal
- Breaker operating times
- Any other schemes that are part of or impact the UVLS Programs, such as related generation protection, islanding schemes, automatic load restoration schemes, UFLS, and RAS.

Additionally, the UVLS Program database should be updated annually (once every calendar year) by the Planning Coordinator. The intent here is for UVLS entities to review the data annually and provide changes to the Planning Coordinators so that Planning Coordinators can keep the databases current and accurate for performing event analysis and other assessments.

Finally, a Planning Coordinator is required to provide information to other Planning Coordinators and Transmission Planners within its Interconnection, and other functional entities with a reliability need, within 30 calendar days of receipt of a written request. Thirty calendar days was selected as the time frame as it is considered to be reasonable and well-accepted by the industry. Also, this requirement of sharing the database with applicable functional entities supports the directive provided by FERC that requires an integrated and coordinated approach to UVLS programs (Paragraph 1509 of FERC Order No. 693).

Version History

Version	Date	Action	Change Tracking
0	April 1, 2005	Effective Date	New
0	February 8, 2005	Adopted by NERC Board of Trustees	
0	March 16, 2007	Approved by FERC	
0	February 7, 2013	R2 and associated elements approved by NERC Board of Trustees for retirement as part of the Paragraph 81 project (Project 2013-02) pending applicable regulatory approval.	
0	November 21, 2013	R2 and associated elements approved by FERC for retirement as part of the Paragraph 81 project (Project 2013-02)	

Guidelines and Technical Basis

1	November 13, 2014	Adopted by NERC Board of Trustees	Revisions made under Project 2008-02: Undervoltage Load Shedding (UVLS) & Underfrequency Load Shedding (UFLS) to address directive issued in FERC Order No. 763. Completed revision, merged and updated PRC-010-0, PRC-020-1, PRC- 021-1, and PRC-022-1.
1	November 19, 2015	FERC approved PRC-010-1. Docket Nos. RM15-7-000, RM15-12-000, and RM15-13-000. Order No. 818	

Rationale:

During development of this standard, text boxes were embedded within the standard to explain the rationale for various parts of the standard. Upon BOT approval, the text from the rationale text boxes was moved to this section.

Rationale for Applicability

This standard is applicable to Planning Coordinators and Transmission Planners that have or are developing a UVLS Program, and to Distribution Providers and Transmission Owners responsible for the ownership, operation, or control of UVLS equipment as required by the UVLS Program established by the Transmission Planner or Planning Coordinator. These Distribution Providers and Transmission Owners are referred to as UVLS entities for the purpose of this standard.

The applicability includes both the Planning Coordinator and Transmission Planner because either may be responsible for designing and coordinating the program based on agreements, memorandums of understanding, or tariffs.

The phrase “Planning Coordinator or Transmission Planner” provides the latitude for applicability to the entity that will perform the action. The expectation is not that both parties will perform the action, but rather that the Planning Coordinator and Transmission Planner will engage in discussion to determine the appropriate responsible entity.

Rationale for R1

Guidelines and Technical Basis

In Paragraph 1509 from Order No. 693, FERC directed NERC to require an integrated and coordinated approach to all protection systems. The drafting team agrees that a lack of coordination among protection systems is a key risk to reliability, and that each Planning Coordinator or Transmission Planner that develops a UVLS Program should evaluate the program's viability and effectiveness prior to implementation. This evaluation should include studies and analyses used when developing the program that show implementation of the program resolves the identified undervoltage conditions that led to its design. These studies and analyses should also show that the UVLS Program is integrated through coordination with generator voltage ride-through capabilities and other protection and control systems. Though presented as separate items, the drafting team recognizes that the studies that show coordination considerations and that the program addresses undervoltage issues may be interrelated and presented as one comprehensive analysis.

In addition, Requirement R1 also requires the Planning Coordinator or Transmission Planner to provide the UVLS Program's specifications and implementation schedule to applicable UVLS entities to implement the program. It is noted that studies to evaluate the effectiveness of the program should be completed prior to providing the specifications and schedule.

Rationale for R2

UVLS entities must implement a UVLS Program or address any necessary corrective actions for a UVLS Program according to the specifications and schedule provided by the Planning Coordinator or Transmission Planner. If UVLS entities do not implement the UVLS Program according to the specifications and schedule provided, the UVLS Program may not be effective and may not achieve its intended goal.

Rationale for R3

A periodic comprehensive assessment (detailed analysis) should be conducted to identify and catalogue the accumulated effects of minor changes to the system that have occurred since the last assessment was completed, and should include an evaluation of each UVLS Program to ensure the continued integration through coordination. This comprehensive assessment supplements the NERC Reliability Standard TPL-001-4 annual assessment requirement to evaluate the impact of protection systems.

Based on the drafting team's knowledge and experience, and in keeping with time frames contained in similar requirements from other PRC Reliability Standards, 60 calendar months was determined to be the maximum amount of time allowable between assessments. Assessments will be performed sooner than the end of the 60-calendar month period if the Planning Coordinator or Transmission Planner determines that there are material changes to system topology or operating conditions that affect the performance of a UVLS Program. Note that the 60-calendar-month time frame would reset after each assessment.

Rationale for R4

A UVLS Program not functioning as expected during a voltage excursion event for which the UVLS Program was designed to operate presents a critical risk to system reliability. Therefore, a timely assessment to evaluate whether the UVLS Program resolved the undervoltage issues associated with the applicable event is essential. The 12 calendar months (from the date of the event) provides adequate time to coordinate with other Planning Coordinators, Transmission Planners, Transmission

Guidelines and Technical Basis

Operators, and UVLS entities, simulate pre- and post-event conditions, and complete the performance assessment.

Rationale for R5

If program deficiencies are identified during an assessment of a UVLS Program performed in either Requirement R3 or R4, the Planning Coordinator or Transmission Planner must develop a Corrective Action Plan (CAP) to address the deficiencies. Based on the drafting team's knowledge and experience with UVLS studies, three calendar months was determined to provide a judicious balance between the reliability need to address deficiencies expeditiously and the time needed to consider potential solutions, coordinate resources, develop a CAP and implementation schedule, and provide the CAP and schedule to UVLS entities.

It is noted that the three-month time frame is only to develop the CAP and provide it to UVLS entities and does not encompass the time UVLS entities have to implement the CAP. Requirement R2 requires UVLS entities to execute the CAP according to the schedule provided by the Planning Coordinator or Transmission Planner.

Rationale for R6

Having accurate and current data is required for the Planning Coordinator to perform undervoltage studies and for use in event analyses. Requirement R6 supports this reliability need by requiring the Planning Coordinator to update its UVLS Program database at least once each calendar year.

Rationale for R7

Having accurate and current data is required for the Planning Coordinator to perform undervoltage studies and for use in event analyses. Requirement R7 supports this reliability need by requiring the UVLS entity to provide UVLS Program data in accordance with specified parameters.

Rationale for R8

Requirement R8 supports the integrated and coordinated approach to UVLS programs directed by Paragraph 1509 of Order No. 693 by requiring that UVLS Program data be shared with neighboring Planning Coordinators and Transmission Planners within a reasonable time period. Requests for the database should also be fulfilled for those functional entities that have a reliability need for the data (such as the Transmission Operators that develop System Operating Limits and Reliability Coordinators that develop Interconnection Reliability Operating Limits).